

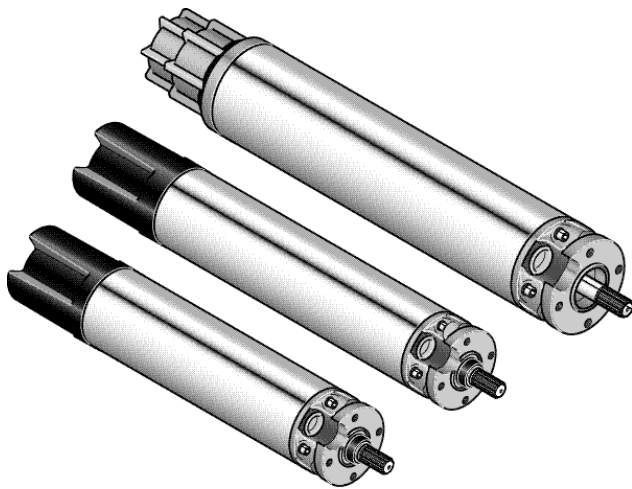

6" and 8" Encapsulated Submersible Motors



— Assembly and operating instructions —

A - Strictly observe!	2
Intended use, typical use, permitted / prohibited media, requirements of the EC-regulation "machines"	
B - Technical information	5
Technical data, dimensional drawings, differences between the model variations, options	
C - Storage and unpacking	6
Storage conditions, unpacking, inspection	
D - Assembling the motor	7
Required tools, inspection before assembly, checking and topping off the motor fluid, assembly of motor and pump, connecting and extending the motor cable, measuring the insulation resistance	
E - Electric connection	14
Requirements for power supply, fuses and motor protection, earthing, surge voltage protection, connection of different model variants, connector pinout, determining rotation, connection of frequency converters and soft starters	
F - Operation	19
Checks before power up, switching sequence in case of generator operation, starting the motor	
G - Trouble shooting	20
Safety during maintenance work, what to do in case of electrical, mechanical or hydraulic problems	

Attention: The motors may only be used under strict observation of these instructions. Keep this manual close at hand, so that you have it available whenever questions arise!

1. Intended use

Electric submersible motors made by Franklin may be used to drive pump loads under water only.

a) Typical application:

Typical applications for loads (e.g. pumps) driven by submersible motors are:

- **drinking water supply** in cities and villages, even pumping out of rivers,
- **wells** in waterworks, private households and agriculture,
- **stirring machines** in water treatment plants,
- **water supply** for dairies, breweries and mineral water bottling plants as well as in industrial cooling circuits,
- **ground water heat pump systems**
- **irrigation sprinkling systems** in gardening, agriculture and forestry as well as for fish ponds,
- **dewatering** in civil engineering and mining,
- **pressure boosting systems** in industrial application (with pump inside pressure shell),
- **fountains**, also for horizontal installation. Note: In such a case you must strictly observe the regulations concerning the safety of electric installations for fountains.

b) Permitted media

Submersible motors may **only** be used in clean and low viscosity fluids, such as

- **drinking water** and **water for industrial use**.

c) Non-permitted media

Submersible motors must not be used under any circumstances in any other media

- especially not for the pumping of **air**, **explosive media** or **waste water**.
- For the use in **aggressive media** there are motors available, which are made of V4A-steel (AISI 316). The person ordering the motor is solely responsible for choosing the material. **Corrosion may occur even with V4A-steel.**

d) Temperature of medium

The **temperature of the medium** may be between **0 ... +30 °C**. Temperatures down to -8 °C are only permitted with the original filling solution of the motor.

A coolant flow speed of 0,16 m/sec. (minimum) along the motor must be assured. Otherwise the motor will overheat.

e) Cooling tube or flow sleeve

The coolant flow speed results from the diameter of the well and the displacement of the pump.

If the required minimum speed of the coolant flow cannot be achieved, e.g. if the inlet opening of the well is above the motor or if the well has a very large diameter, a cooling tube or flow sleeve is required.

This should enclose the motor completely and the water inlet opening of the pump in such a way, that the motor is positively cooled (see illustration).

The tube may be made of a corrosion resistant steel or plastic.

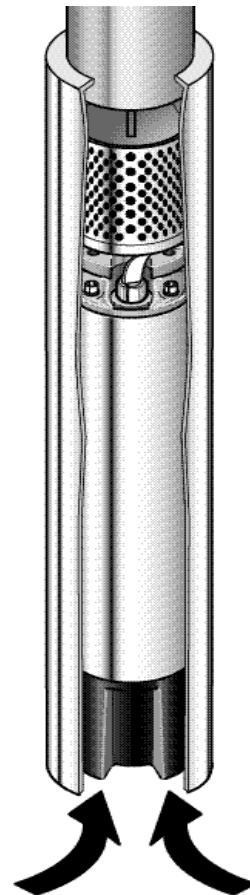

f) With higher temperatures of the medium operation is only permitted if you **reduce the load** in accordance

- with **table 1** with a coolant speed of min. **0,16 m/sec.**
- with **table 2** with a coolant speed of min. **1 m/sec.**

Water temperature [°C]	Maximum Motor load	
	Motor rating 5,5 ... 22 kW	Motor rating >22 kW
35	100%	88%
40	88%	76%
45	76%	62%
50	62%	48%
55	48%	20%
60	20%	--

Table 1: Maximum loading capacity in % of the nominal power at a coolant flow speed of 0,16m/sec.

Water temperature [°C]	Maximum Motor Load	
	Motor rating 5,5 ... 22 kW	Motor rating >22 kW
35	100%	100%
40	100%	100%
45	100%	88%
50	88%	76%
55	76%	62%
60	62%	48%

Table 2: Maximum loading capacity in % of the nominal power at a coolant flow speed of 1m/sec.



Attention!

Under no circumstances may the motor be heated to more than +60 °C - neither during operation, nor during storage! Otherwise motor fluid may be lost due to expansion - the motor would be damaged after a short period of use!

2. Requirements during use

The **maximum submersion depth** below the water level must not exceed **350 m**.

If a deeper submersion depth (down to 1000 m) is required, you may order specially tested motors with pre-assembled cables from the manufacturer.

- The **frequency of starting must be limited to 20 starts** per hour - with an **On/Off time** of minimum at least **90 seconds**.
- **You should generally plan the installation of a check valve** in the riser pipe or drop pipe, if the pump is not already fitted with one. Spring loaded check valves are recommended to minimize water hammering at shut off.
- The distance between check valve and pump must not exceed **7 m**.
- In wells with variable water supply we recommend the installation of a level switch, to avoid **dry running** of motor and pump.
- In applications where the water supply may be insufficient to meet the pump output, running protection must be supplied. This is typically of a level sensor or flow switch

3. Duties of the personnel

For the operating steps described in this manual **expert knowledge** equivalent to a professional education of a **skilled electrician** or a **technician for electric machinery** is required.

- You should therefore perform these steps yourself, only if you have such **expert knowledge**,
- or have the work performed by **personnel** with such expert knowledge.



Demands of the EC-regulations

Submersible motors are components, which are in accordance with the EC-regulations for machines. You may only start to operate the motor, if ...

- you have manufactured a **complete machine**, e.g. in connection with the aggregate to be driven.
- the **protection requirements** demanded by the applicable EC- and local regulations are met,
- you have confirmed the protection requirements by issuing the **EC declaration of conformity**
- and you have made it clearly visible by attaching the **CE-sign** from outside.

4. Instructions for the reader!

Before unpacking, installing or operating the submersible motor:

Please strictly observe the information in this manual!

The non-observance of this manual may lead to errors during operation,

- **threats** to health and life may be caused by electrical or mechanical influences,
- **damage** to motor or surrounding installations and
- **functional faults** during operation.

When working on electric equipment or when ordering others to do such work you should always remember that you have a **responsibility** for the people around you!

1. For all models:

Design principle: Enclosed 2-pole asynchronous motor with water lubricated plain bearings.

Model - No.: 6": 236...
8": 239...

Voltage range: 220V...690V; 3~ 50Hz/60 Hz

Starting variants: Direct starting (DOL)
Wye-delta starting

Rotary speed: ~ 2860 rpm at 50 Hz
~ 3450 rpm at 60 Hz

Weight: See technical data sheets

Power: 6": 4 ... 45kW
8": 30 ... 150kW

Connection: 6"/8" NEMA flange

Type of protection: IP 68

Insulation class: F

Ambient temperature: max. +30 °C

Coolant speed: min. 16 cm/sec.

Frequency of starts: max. 20 switching operations per hour with a minimum On/Off time of 90 seconds

Installation position: vertical (shaft always upwards, never downwards) and slightly vertical in case of horizontal installation.

Temperature monitoring: 6": 37kW and 45kW as well as 8" motors Subtrol temperature sensor to 110 kW

Voltage tolerance: +6% / - 10% $U_{nominal}$

Cable: KTW and VDE tested cables

6": motor cable not in scope of delivery.
8": motor cable (8 m) part of scope of delivery.
Earth conductor not in scope of delivery.

Noise level: < 70 dB(A)

Maximum axial thrust: depending on model

towards motor: 6": 6.500N, 15.500N, 27.500N
8": 45.000N

from motor*: 6": 1.400N
8": up to 75 kW 1.400N
8": 93 to 150 kW 3.400N

*Note: These data apply for a load time of **max. 3 minutes**. This time is sufficient to start the pump.

Motor filling: The composition of the fluid is in accordance with the food protection legislation. The

filling may be replaced by drinking water. Observe frost protection!

For all models:

The 6" and 8" motors are three-phase motors with hermetically enclosed stator. The specification 6" or 8" refers to the smallest possible well tube inside diameter into which the motor can be inserted. For correct dimensions please refer to the drawings and the technical data sheets for the respective motor model.

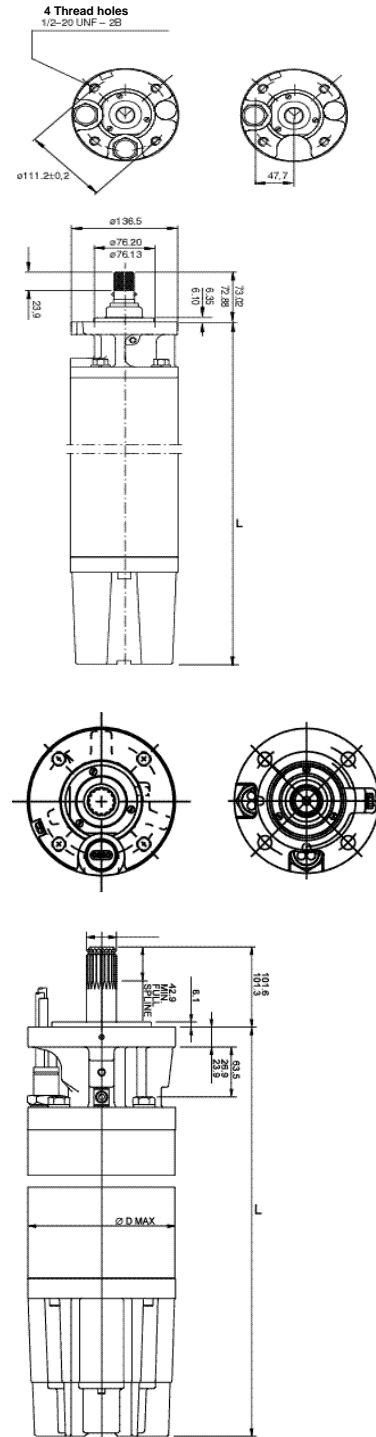

2. Options

6“ motors:

- PTC temperature sensor 4kW ... 30kW,
Subtrol temperature sensor 4kW ... 30kW
- Special materials: AISI 316 SS (with SIC rotating mechanical seal for 4kW ... 30kW)
- Motors with SIC rotating mechanical seal, special voltages, motor cable 4m and special lengths

8“ motors:

- Special materials: AISI 316 SS
- Motors with SIC rotating mechanical seal
- special voltages
- earth conductor

1. Storing the motor

Correct storage of the motor is a prerequisite for trouble free operation at a later date.

- Leave the motor in its **original packaging** until the day of installation.
- When standing the motor upright make sure that it **cannot fall over** (shaft always upwards).
- Do not subject the motor to direct sunlight or other heat sources. **Under no circumstances may the motor be heated up higher than 60°C.** Otherwise motor fluid may escape because of expansion, the motor would be damaged during later use.
- Make sure that the **storage temperature** with original filling does not drop below **-40°C**. If the filling has been replaced by **water**, the motor must be stored in a **frost-protected** environment - i.e. do not store below 0°C.

2. Unpacking the motor



Risk of injury!

- Mind the weight of the motor.
- Use only permitted lifting gear.
- Do not step under loads being lifted.
- Take the motor carefully out of its packaging in order to avoid damage.

3. Check

after unpacking for apparent external damage.

1. Required tools

For the necessary inspections and correct assembly the following tools are required:

- Filling syringe (308 622 121)
- Test pin (308 343 903) / (308 343 904)
- Insulation measuring unit 500V test, display up to min. 200 M Ohm

2. Inspection before assembly

If the motor is older than one year (e.g. in case of reuse or after longer storage), the motor filling must be checked before installation:

a) Determine the age of the motor

The age of the motor can be taken from the DATE CODE, which is engraved above the Motor nameplate.

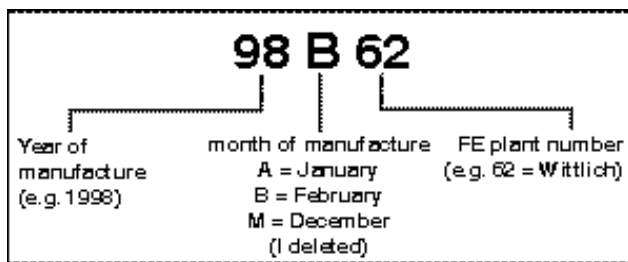

b) Check the motor fluid

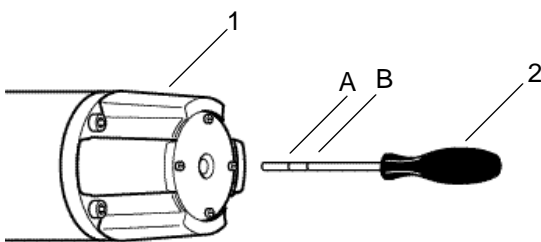

1. Place the motor horizontally.
2. Insert the **test gauge** (2) through the bore in the **diaphragm cover** (1), until a resistance can be felt.

The **filling level** is sufficient, when the diaphragm is adjusted to the following distance:

Diaphragm distance:

- 6" standard motor 59mm +/- 2mm
- 6" AISI 316 SS 19mm +/- 2mm
- 8" type 1: 93kW ... 150kW 38mm +/- 3mm
- 8" type 2: 30kW ... 75 kW 35mm +/- 3mm

c) Topping off the motor fluid

If the inspection has revealed that the motor fluid level is too low (distance between diaphragm and housing bigger than stated above), you may top off with clean tap water - **do not use distilled water!**

However, more suitable is the original filling fluid from Franklin Electric, because only this fluid ensures sufficient frost protection.

- 6" and 8" motors:**
- 5 l (308 353 921);
 - 10 l (308 535 922);
 - 20 l (308 353 922)



Risk of injury!

Make sure that the motor cannot fall over.

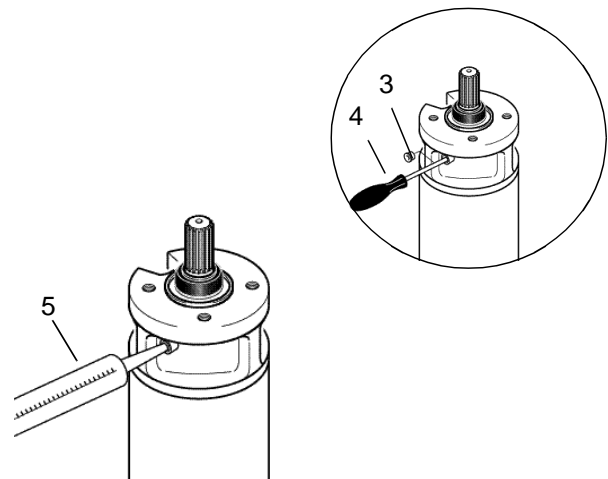

1. Stand the motor **carefully** vertically on the diaphragm cover. Take care to prevent the motor from falling.
2. Carefully lift out the **filter screen insert** (3) with a screwdriver.
3. Then press with the test pin lightly into the **valve** (4) underneath.

This purges the inside of the motor.

4. Attach the **filling syringe** (5) and top off with motor fluid - until the required filling level is reached.
5. Finally **check** the filling level again, as described above.

3. Assembly of motor and pump (load and device)



Attention!

With some devices the power supply plug is no longer accessible after assembly. In such a case you should **first connect the motor cable** as described below.

This manual can only describe the work steps related to the motor. Please observe also the **installation instructions for the load device** when assembling motor and aggregate.

Caution!

For your safety!

Do not use the motor with damaged devices or parts. The high drive forces may otherwise cause **accidents** with considerable risk of injury and **danger to life!**

a) Preparatory tests

1. If necessary remove the shaft guard.
2. Before assembly turn the motor shaft by hand - it must rotate freely after overcoming the static friction.
If not, perform trouble shooting, free the shaft and continue
3. Make sure that the surfaces of the parts to be connected are free of dirt and dust.

b) Assembly

1. Cover the inner part of the coupling on the load with a water resistant, acid-free grease (e.g. Mobil FM 102, Texaco Cygnus 2661, Gleitmo 746).

The grease minimizes the friction and provides additional protection against sand entry.

During assembly of motor and pump unit make sure that the splined section is provided with an O-ring. This O-ring prevents sand and dirt from entering into the splined section of the shaft. The appropriate couplings are available from Franklin Electric.

2. Align the shafts of pump and motor to each other and join pump and motor together.



Attention!

The shafts of pump and motor must not have a **rigid connection** (coupling) in axial direction.

The coupling should be fixed on the pump shaft and free to slide on the motor shaft.

Use fastening screws of appropriate **quality, class** and **dimensions**, as specified by the manufacturer of the load device.

Observe the **tightening torques** specified by the manufacturer of the load device.

Note: Mounting bolts for load device assembly

6" motors: Screw thread 1/2" - 20 UNF-2B
8" motors: Bore \varnothing 17,5 mm

3. Bolt motor and pump together and tighten the fastening screws crosswise as specified.

c) Final tests

If the coupling is freely accessible during operation, it is absolutely necessary to install a guard **against touching!**

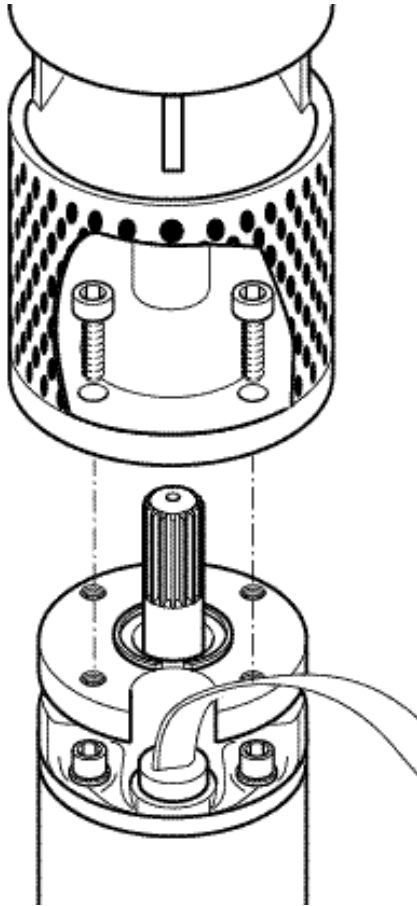

4. Connecting the motor cable

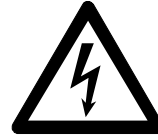

Threat to life!

The cable must under no circumstances be able to touch sharp edges.

Should this danger arise, you must first protect the cable with a sufficient padding, e.g. a piece of rubber.

Route the cable along the pump and protect it with a cable guard against damage. Please observe also the specifications of the pump manufacturer.

This step requires strict cleanliness. Dampness and dirt or grease on plug and socket contacts can be the cause for malfunctions and failures.

- You should always use genuine cables from Franklin Electric - these are **suitable for drinking water** and VDE-tested. Other cables may not be sufficiently safe and suitable!

a) Connect the cable to the motor (6" motors only)

1. Remove the plastic plug (1), see illustration on page 10.
2. Check both plug (2) and socket (3) for dirt and dampness.
3. Slide the jam nut of plug (2) so far back, that the plug is free.
4. Cover the outer circumference of the rubber part on the plug slightly with silicon or Vaseline. Make sure that the **contacts remain free of grease**. Otherwise there may be a short circuit. On AISI 316 motors apply some grease also to the thread of the jam nut.
5. Then insert the plug as deep into the socket (3) as possible, until the thread in the socket is visible again and slide the jam nut over the plug (4).
6. Turn the jam nut **first** in anti-clockwise direction to find the beginning of the thread. Then tighten the nut by hand in clockwise direction.
7. Tighten the spigot nut with an open end spanner (30 mm), until an initial compression of the plug rubber can be felt.

8. Tightening the jam nut (4) for another 1/2 turn will seal the plug.

On the 8" model the motor cable is already connected ex-factory. In this case you may jump the following paragraph. For all other models:

Note: Steps 2 to 8 describe also the assembly of a spare cable for an 8" motor.

Torque: 160 -200 Nm



Attention!

For 6" motors:

Do not tighten more than 68 - 91 Nm, otherwise the plug seal will be damaged.

9. 8" DOL motors (110kW - 150kW) are fitted with 3 individual plugs. Insert the plugs and fasten them with the pressure plate and the 4 screws. The tightening torque is 9 - 10Nm. Tighten the screws crosswise.

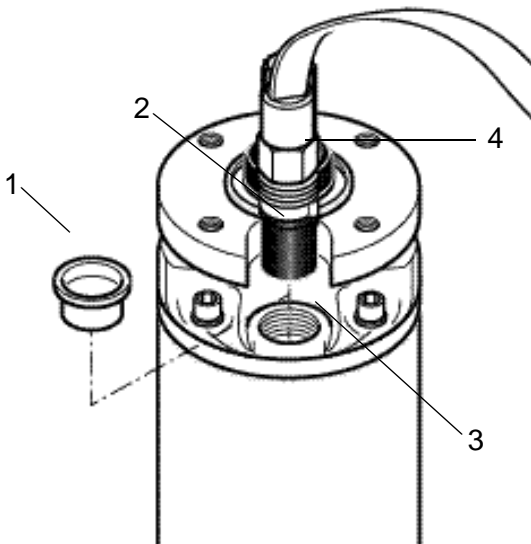

b) Connecting the earth conductor



Attention!

8" motors are supplied without earth conductor.

The customer is responsible for the correct connection of an earth conductor. For this purpose the motor is fitted with the respective PE-terminal.

c) Extending the motor cable

The customer can extend the cable supplied with the motor.



Attention!

During operation the cable supplied with the motor must always be **covered** by the pumped fluid for cooling.

Use **only** extension leads which are

- made of suitable **material** for the application
- of sufficient insulation for the **temperatures** in the medium.

Protect the cable connection against water. For this purpose **shrink tubes, casting compounds** or prefabricated **cable armatures** are commercially available.

When choosing such items ensure sufficient **voltage resistance**, but also their **suitability** for the medium (particularly in the case of drinking water).

Observe the instructions of the respective supplier about the use of insulation material.

For the required **cable cross-sections** tables 3, 4, 5 and 6 are only recommendations. The electrician is solely responsible for choosing and dimensioning the cable.

The minimum cross-section is specified according to IEC 364 (VDE 0298 part 4).

In this context you should also take the notes of the pump manufacturer into consideration.

d) Measuring the insulation resistance

Perform this measurement before and while **lowering** the completely assembled unit at the place of installation.

Use a megohm meter (megger) to measure the insulation resistance between the motor lead conductors and the earth ground conductor.

1. Make sure that electrical power is off and locked out.
2. Make sure that the measurement points on the conductors are clean.
3. Verify proper operation of the meter according to the manufacturing instructions.
4. Measure the insulation resistance from each power conductor to the earth conductor before lowering the assembled unit and compare the measured values to the chart below.
5. Continue to lower the unit into installation, periodically repeating step 4.

Acceptable insulation resistance	
Motor	value
new, without cable	200 MOhm
installed, with cable	20 MOhm
used, installed with cable	2 MOhm

**400 V / 50 Hz
Direct starting**

Nominal motor power			Cable cross-section [mm ²]									
	kW	min. cross-section in mm ²	1,5	2,5	4	6	8,4	10	16	25	35	50
6"	4	1,5	110	180	290	430	588	700	1100	1660	2260	0
	5,5	1,5	80	130	210	310	425	500	790	1200	1630	2230
	7,5	2,5	0	100	160	230	322	380	590	900	1220	1670
	9,3	2,5	0	80	130	200	271	320	510	780	1070	1470
	11	2,5	0	70	110	170	229	270	430	660	900	1240
	15	6	0	0	0	120	177	210	320	490	670	930
	18,5	6	0	0	0	100	140	170	260	400	550	750
	22	8,4	0	0	0	0	117	140	220	340	460	640
	30	16	0	0	0	0	0	0	170	260	350	480
	37	16	0	0	0	0	0	0	140	210	280	390
45	25	0	0	0	0	0	0	0	170	240	330	
Cable cross-section [mm²]			1,5	2,5	4	6	8,4	10	16	25	35	50

Table 3: Maximum cable lengths for 6" motors with direct starting, a voltage of 400 V/50 Hz and a voltage drop of 5%.

You should take the min. cross-section acc. to IEC364 (VDE298 part 4) into account.

Nominal motor power			Cable cross-section [mm ²]									
	kW	min. cross-section in mm ²	16	25	35	50	70	95	120	150	185	240
8"	30	16	170	260	350	480	640	820	980	1160	1340	1590
	37	16	140	210	280	390	530	680	810	960	1110	1310
	45	25	0	170	240	330	440	560	670	800	920	1090
	56	35	0	0	190	270	360	460	550	660	760	910
	75	50	0	0	0	200	270	350	420	500	580	700
	93	70	0	0	0	0	210	270	320	380	440	530
	110	95	0	0	0	0	0	230	280	330	380	450
	150	120	0	0	0	0	0	0	210	260	300	360
Cable cross-section [mm²]			16	25	35	50	70	95	120	150	185	240

Table 4: Maximum cable lengths for 8" motors with direct starting, a voltage of 400 V/50 Hz and a voltage drop of 5%.

If the operating voltage U_B in your installation differs from the nominal voltage U_N , you can calculate the permissible maximum length L_{MAX} as follows:

$$L_{Max} = L_{TAB} (U_B / U_N)^2$$

L_{TAB} = table value

You should take the min. cross-section acc. to IEC364 (VDE298 part 4) into account.

**400 V / 50 Hz
Wye-delta starting**

Nominal motor power			Cable cross-section [mm ²]									
	kW	min. cross-section in mm ²	1,5	2,5	4	6	8,4	10	16	25	35	50
6"	4	1,5	160	270	430	640	887	1050	1650	2500	0	0
	5,5	1,5	120	190	310	460	939	760	1190	1800	2440	0
	7,5	1,5	90	150	230	350	481	570	890	1350	1830	2500
	9,3	1,5	70	120	200	300	411	490	770	1170	1600	2210
	11	1,5	60	100	170	250	345	410	650	990	1350	1870
	15	2,5	0	80	130	190	261	310	490	740	1010	1400
	18,5	2,5	0	60	100	150	210	250	390	600	820	1130
	22	4	0	0	90	130	177	210	330	500	690	960
	30	6	0	0	0	100	135	160	250	380	520	720
	37	8,4	0	0	0	0	112	130	210	310	430	590
45	10	0	0	0	0	0	110	170	260	360	490	
Cable cross-section [mm ²]			1,5	2,5	4	6	8,4	10	16	25	35	50

Table 5: Maximum cable length for 6" motors with wye-delta starting, a voltage of 400 V/50 Hz and a voltage drop of 5%.

You should take the min. cross-section acc. to IEC364 (VDE298 part 4) into account.

Nominal motor power			Cable cross-section [mm ²]											
	kW	min. cross-section in mm ²	8,4	10	16	25	35	50	70	95	120	150	185	240
8"	30	8,4	135	160	250	380	520	720	960	1240	1480	1740	2020	2390
	37	8,4	112	130	210	310	430	590	790	1010	1210	1430	1660	1970
	45	8,4	93	110	170	260	360	490	660	850	1010	1190	1380	1640
	56	16	0	0	140	210	290	400	540	690	830	990	1150	1370
	75	25	0	0	0	160	220	300	410	530	630	750	880	1040
	93	35	0	0	0	0	170	240	320	410	490	570	670	790
	110	50	0	0	0	0	0	200	270	350	410	490	570	670
	150	95	0	0	0	0	0	0	210	270	320	380	450	540
Cable cross-section [mm ²]			8,4	10	16	25	35	50	70	95	120	150	185	240

Table 6: Maximum cable lengths for 8" motors with wye-delta starting, a voltage of 400 V/50 Hz and a voltage drop of 5%.

If the operating voltage U_B in your installation differs from the nominal voltage U_N , you can calculate the permissible maximum length L_{MAX} as follows:

$$L_{Max} = L_{TAB} (U_B / U_N)^2$$

L_{TAB} = table value

You should take the min. cross-section acc. to IEC364 (VDE298 part 4) into account.

1. In this chapter it is assumed that

- the motor is correctly assembled, as described in chapter D,
- the insulation resistance of the motor cable has been measured and found in good condition, as described in chapter D,
- the completely assembled aggregate has been correctly installed at the place of use, as described in the instructions of the manufacturer.

- The total voltage tolerance must be within the range from -10% to +6% (measured on the motor terminals).
- The deviation of the motor current from the average value of all three currents must not exceed max. $\pm 5\%$.

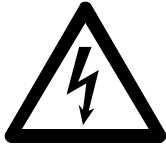

Caution!

For your safety!

Before making any connections you must assure:

that the complete system is electrically dead and

that nobody is able to accidentally switch the power on, while work on the system is in progress.

Do not work on electric installations if there is the risk of a thunderstorm or during a thunderstorm. Lightning may cause dangerous surge voltage.

There is an **acute threat to life** by electric shock if you do not observe these notes.

2. The power supply

must at least meet the following demands, to avoid damage to motor and undesired feedback effects to the supply network:

a) Power supply by mains connection

The following tolerances must not be exceeded, as otherwise the motor may be damaged:

b) Power supply by generator



Attention!

The applicable tolerances from mains supply must also be applied by power supply via generators!

When operating a motor via a generator please bear in mind that the starting current of the motor is five times the nominal motor current and that a mean cos phi of 0,6 for starting can be expected.

Also make sure that a sufficient generator power is permanently available (see table 7), and that for starting the voltage must be at least 55% of the nominal motor nameplate voltage.

Motor power [kW]	Generator power [kVA]
3,7	18,75
5,5	25
7,5	37,5
11	50
15	75
18,5	94
22	125
30	125
37	188
45	220
55	313
75	375
93	469
110	563
130	656
150	750

Table 7: Required permanent generator power

3. Connecting the motor

Observe the specifications of the motor type plate and dimension the electric installation accordingly.

The following connection examples refer solely to the motor - they are no recommendations for any preceding control elements!

The person performing the installation is solely responsible for the correct planning and installation.

a) Fusing and motor protection

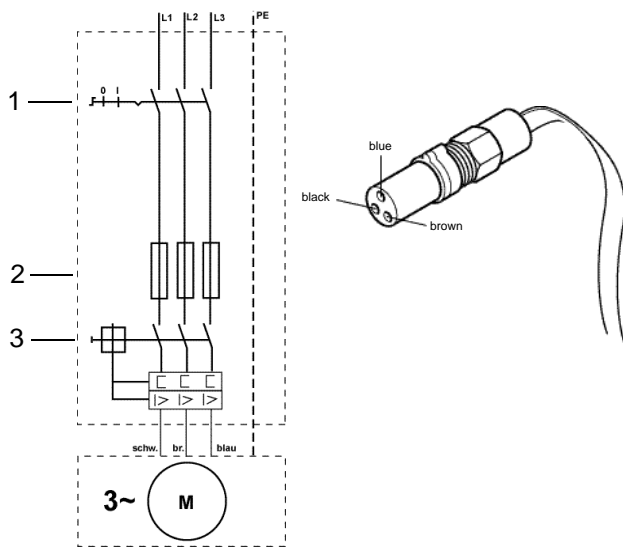

Consider the installation of an external **main switch (1)**, to be able to disconnect the voltage supply at any time - e.g. in case of danger or when working on the installation.

Plan **fuses (2)** for each individual phase at the customer's site.

Plan the installation of a **motor starting and protection switch (3)**, as explained in the following description for the individual models. You should also plan the installation of an **emergency shut-off**, as far as this is specified or found necessary for your application!

b) Earthing

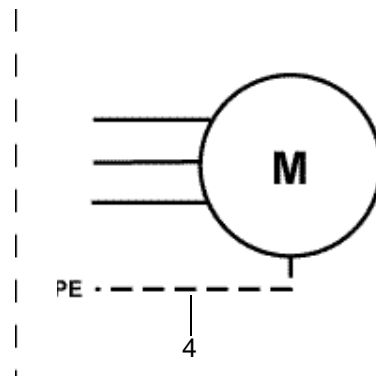

During the **dimensioning** of the earth connection particularly consider the motor power.

Expert rules can be found in EN 60099 (VDE 0675) and IEC 64 (VDE 0100) and in the European standards.

The motor must be earthed. Provide a correct **protective conductor connection (4)** according to IEC 64 (VDE 0100) - particularly for a good contact!

c) Surge voltage protection

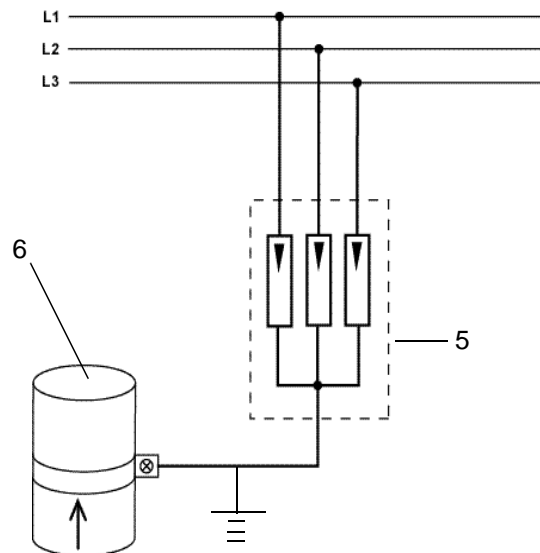

Provide a sufficient **surge voltage protection (lightning protection) (5)** in the voltage supply, by connecting the pipe (6) to ground.

d) 6" and 8" 3-phase model

Franklin Electric motors are suitable for both clockwise and anti-clockwise rotation -depending on the connection:

The motor **rotates in anti-clockwise direction** (looking onto the motor shaft), if ..

- the conductor sequence L1 - L2 - L3 provides a **right-hand field** (can be checked with a rotating field tester)
- and you connect the motor as shown (L1-U,L2-V,L3-W).

The motor rotates **in clockwise direction**, (looking onto the motor shaft), if

- the conductor sequence L1 - L2 - L3 provides a **left-hand field** when connecting the motor as shown,
- or if you exchange any **two conductors** (e.g. L3 - U, L1- W) in a **right-hand field**.

Connect the **motor** that the sense of rotation matches the load requirements. The connection examples show the common connection for a right-hand field and an anti-clockwise rotation.

e) Direct starting

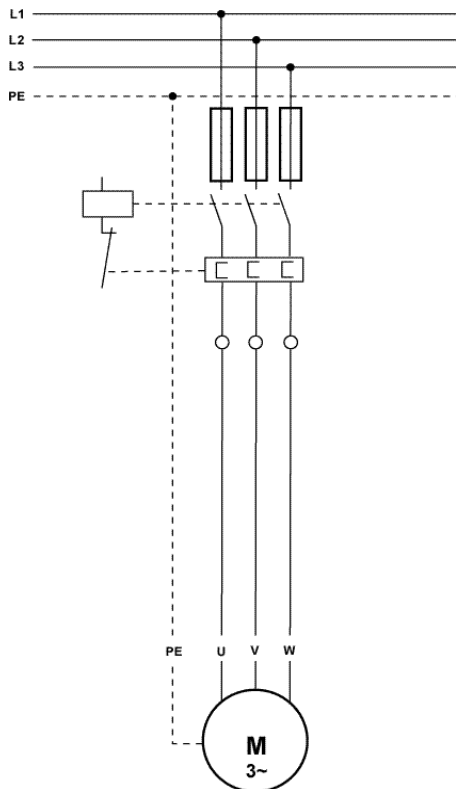

f) Wye-delta starting

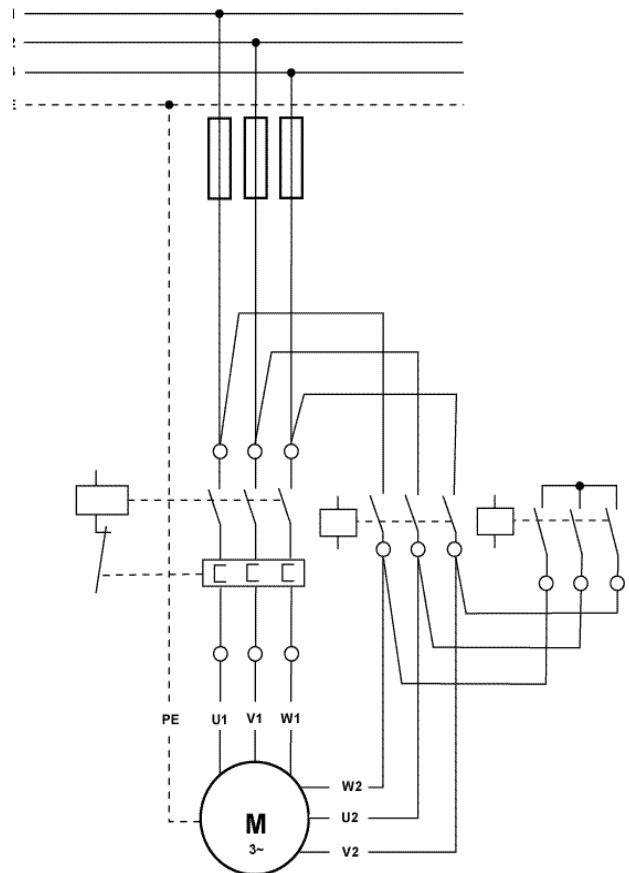

A **motor protection switch** (over load relay) is strictly required!

For this purpose

- use only **thermal overload switches** with a temperature compensation of 20 °C to 40 °C of triggering class A or 10, according to EN 60947-4-1 (acc. to VDE 0660 part 102),
- with a **tripping time** of 10 seconds at 500% I_N (referring to cold condition of the bimetals).
- and which are phase-insensitive.

Adjust the motor protection unit to the value of the measured operating current, but **never exceed nominal motor current I_N** (acc. to motor nameplate). We recommend an adjustment to 90% of the nominal motor current.

g) Operation with frequency converter

If you want to operate the motor with a frequency converter for variable control of rotary speed, you must observe the following points:

- Make sure that during operation with the frequency converter at lowest pump output a minimum **coolant flow speed** of 16cm/s is ensured. The **load** on the motor should not exceed the motor nameplate maximum amps at rated voltage and frequency.
- Adjust the frequency converter so that the **limiting values of min. 30 Hz and max. 60 Hz** will not be exceeded. For operations above 60 Hz contact FRANKLIN ELECTRIC for approval. The maximum running up time from 0 to 30 Hz and running down time from 30 to 0 Hz for frequency-converter operation is **1 second**.
- You must strictly limit the **voltage peaks** occurring in frequency converter operation to those values described in **EN 60034 (EN 0530 appendix 2)** (the maximum rate of voltage rise **500V/μs** and maximum voltage peak **1000V**).
- According to experience, additional filters are required for cable lengths **longer than 15m** between frequency converter and motor. For further steps required, contact the manufacturer of the frequency converter.
- Observe under all circumstances the instructions for the frequency converter used when connecting up and putting the motor into operation!

h) Connection of soft starting units (soft starters)

If you want to operate the motor with a soft starter, you must observe the following points;

- Set the **starting voltage** of the soft starter to 55 % of the nominal voltage
- and the **acceleration time** as well as the **deceleration time to maximum 3 seconds**.
- After acceleration the soft starter should be **bypassed by means of a contactor**, as otherwise the resulting losses in the motor would be too high. This can lead to **an overheating of the motor at nominal power**.

In this respect consult the manufacturer of the soft starter.

When connecting and commissioning the motor observe strictly the instructions for the respective soft starter!

i) Thermal monitoring

Encapsulated motor	Temperature monitoring system
6" 4kW - 30kW	PTC or Subtrol Plus
6" 37kW - 45kW	Subtrol Plus
8" 30 kW - 110kW	Subtrol Plus

PTC - temperature monitoring 6": 4kW-30kW

The PTC - sensor is located inside the stator windings.

The PTC is a sensor with a low resistance at permissible temperatures and a high resistance when the permissible temperature is exceeded.

Motors with a PTC - sensor are provided with an additional plug connector for an additional two-conductor sensor cable (Franklin, length 4m).

Connecting cable 2x0,75 mm² (model 310 364 004)

The two-conductor cable of the PTC - sensor in the motor must be connected to a PTC - motor protection system.

This protection device (PTC - receiver) is commercially available in good electrical controls shops or from your pump supplier.

Subtrol-Plus temperature monitoring

The Subtrol-Plus sensor is installed inside the stator and sends a high frequency signal via the motor connection cables to the Subtrol-receiver, when the temperature exceeds the permissible limit.

An additional cable for the signal transmission is therefore not required.

The Subtrol - receiver evaluates the signal and protects the motor against:

- excessive temperature
- overloads
- low load (like dry-running)
- frequent start-stop cycles

The Subtrol protection system is available at Franklin Electric.

1. This chapter assumes that

- the motor is correctly assembled with the **aggregate**, as described in chapter D,
- the motor is correctly **connected and fused**, as described in chapter E,
- the **insulation resistance in the motor cable** has been measured and found o.k., as described in chapter E,
- the completely assembled aggregate has been **correctly installed at the place of use**, as described in the instructions of the manufacturer.

2. Before starting to operate the motor

make sure that

- the motor is fully submerged. The motor must only be operated **under water**.
- the **riser pipe or drop has been bled**, to avoid water hammering during starting. Otherwise both aggregate and pumping pipes may be damaged.
- the conditions for commissioning specified by the manufacturer of the pump are met.
- all electric connections and protective installations have been **checked** and fuses and circuit breakers are correctly **adjusted**.
- **access to dangerous points has been eliminated**, particularly to rotating parts, suction ports or pressure outlets and electrical connections.
- for motors with original filling the **temperature of the medium** does not drop below -8 °C and for motors with water filling not below 0 °C.

If not, you must not start to operate the motor, because there is a **risk of accident** and the motor may be damaged.

3. Generator supply

The switching sequence is of utmost importance. If you do not apply this correctly, both motor and generator may be **damaged**.

Therefore:

- Always switch the generator on and off **without load!**

This means:

- **Starting:** always **switch the generator ON first** - and the motor afterwards!
- **Stopping:** always **switch the motor OFF first** - and the generator afterwards!

4. Starting the motor

Once you have checked all above mentioned points and all adjustments are correct, you may start the motor:

- Immediately after starting the motor please check
 - the **operating current** of the motor for each phase,
 - the **mains voltage** while the motor is running,
 - the **level** of the medium to be pumped.
- **Immediately stop the motor**, if
 - the **nominal current** according to the specification on the name plate is exceeded,
 - **voltage tolerances** of more than +6%/-10% of the nominal voltage are measured. For weak supply networks we recommend the installation of a voltage monitor!
 - **dry-running** can be expected. In case of non-uniform supply it is necessary to install a level sensor, as a measure to avoid dry-running.
 - the deviation of a motor current from the average value of all three currents exceeds 5%.

5. During test operation:

Each start applies heat to the motor. Particularly a high frequency of starts contributes to the reduction of the motor lifetime!

You should make sure that the values specified in the technical data concerning the **frequency of starts** are not exceeded, even during test operation!

1. General



Warning!

For your safety!

Please observe the safety regulations mentioned hereunder. Otherwise there is a risk of accident and a threat to life.

- **Do not perform any other work to the motor than the tasks described in this manual.** Otherwise the motor may be damaged, whereby the operating safety of the system can no longer be assured. Due to the partly quite high driving and pumping forces **considerable risks for accidents** may arise, **even danger to life** caused by electric shock.
- For trouble shooting and fault rectification on the complete system you must strictly observe the respective notes in the instruction manual of the pump manufacturer.
- **Do not open the motor!** Without the use of special tools the motor cannot be closed again correctly. This would destroy the motor.
- **Do not carry out any changes or modifications to the motor or the electric connections.** Otherwise the safety of the motor cannot be assured.
- **Work must only be performed when the motor stopped!** No work or inspections are required while the motor is running.
- **The aggregate may be contaminated** when taking it out of a medium, in which health impairing effects cannot be ruled out. **Rests of medium** may accumulate in the bore at the bottom of the **diaphragm cover**, which may drain unexpected.
- **Mark contaminated motors or aggregates,** before handing them over to third persons (e.g. before returning for repair).
- **Disconnect the voltage supply** before starting the work described hereunder.
- Make sure that nobody **can switch the voltage supply back on by accident** while work on the system is still in progress!

- Do not work on electric installations if there is the risk of a thunderstorm or during a thunderstorm.
- Make sure that **all guards and safety installations have been completely reinstalled and are fully functional immediately after completing work.**

2. What to do!

The motor is **maintenance free**. No preventive or regular service work is required.

a) In case of electric problems

e.g. in case of repetitive switching off you should check the insulation resistance by a specialist, as described before.

- Disconnect the motor connection cable from the system and measure **motor and cable**. If the ground to phase insulation resistance is less than 20 MOhm at a new motor and 2 MOhm at a used motor the malfunction must be checked.
- **Is the cable faulty?** Connect a new cable, as described before.
- **Is the motor faulty?** Have the motor checked in a specialist FAM's workshop - or install a new motor.
- **Is it neither motor, nor cable?** Have the electric system checked by a specialist.

b) In case of mechanical or hydraulic problems

e.g. unusual noises, concentricity faults of the pump or frequent on and off switching of the motor, you must perform trouble shooting for the aggregate.

- For this purpose refer to the **instructions of the pump manufacturer.**