



4" SUBMERSIBLE MOTORS FOR COALBED METHANE APPLICATIONS

Three Phase: 3 through 10 horsepower
200, 230, 380, 575 volts - 60 Hertz
460/380 volts - 60/50 Hertz

APPLICATION DATA

These motors are built for superior dependability in 4" diameter or larger coalbed methane wells. Temperature and time rating continuous in 86°F (30°C) water at 1/4 ft. per second flow past motor. Rotation: electrically reversible.

For further information, refer to Franklin Electric's "Submersible Motors: Application, Installation, Maintenance Manual."

BASIC FEATURES

- Corrosion-Resistant Construction
- Stainless Steel Splined Shaft
- Hermetically-Sealed Windings
- Anti-Track Self-Healing Resin System
- Water Lubricated Bearings
- Filter Check Valve
- Kingsbury-type Thrust Bearing Rated for 1500 lbs. Downthrust
- Pressure Equalizing Diaphragm
- Removable Water-Bloc™ Lead
- NEMA Pump Mounting Dimensions
- UL 778 Recognized
- CSA C22.2 #108 Certified

COALBED METHANE MOTOR FEATURES

- Exclusive Sand Fighter™ Sealing System
- Reinforced Diaphragm Housing Resists Damage from Bottom Tagging
- Protective Filter Shields Diaphragm from Debris

WARNINGS: Serious or fatal electrical shock or fire hazard may result from failure to follow the instructions for proper installation and use which accompany this equipment. Do not use motor in swimming areas.



Franklin Electric

4" COALBED METHANE SUBMERSIBLE MOTORS

DIMENSIONS

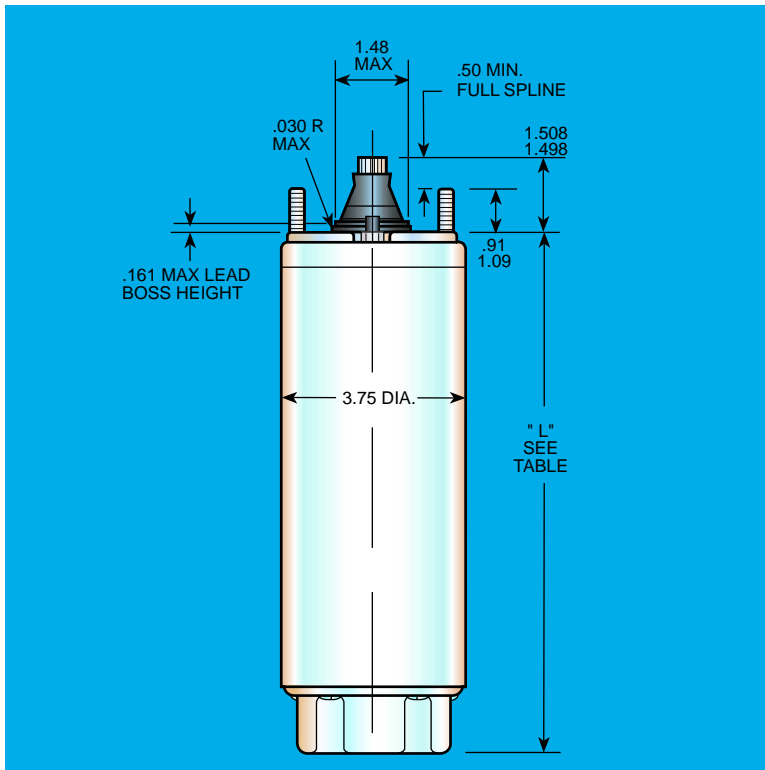

AVAILABILITY

Three-Phase (Special control required)

Hp	kW	"L" Dimension in	Shipping Weight	
			lbs	kgs
3	2.2	19.7	45	20.5
5	3.7	22.7	58	26.4
7.5	5.5	28.7	73	33.2
10	7.5	31.0	78	35.5

60 Hz - 3,450 RPM
50 Hz - 2,875 RPM

NOTE: All dimensions shown in inches.

CONSTRUCTION MATERIALS

Component	Material
1. Top Casting	304 SS
2. Bottom Castings	303 SS Over Iron, Painted Cast Iron
3. Stator Shell	301 SS
4. Stator Ends	Low Carbon Steel
5. Shaft Extension	303 SS, 17-4 SS on 5 - 10 Hp
6. Fasteners	300 Series SS
7. Seal Cover	Sintered Bronze
8. Seal	Sand Fighter™ SiC/SiC Mech Seal
9. Diaphragm	Nitrile Rubber
10. Diaphragm Plate	304 SS
11. Diaphragm Spring	302 SS
12. Diaphragm Cover	304 SS
13. Slinger	Nitrile Rubber
14. Lead Wire (or Cable)	XLPE ^①
15. Lead Potting	Epoxy
16. Lead Clamp	300 Series SS
17. Filter	Delrin & Polyester

^① Removable type leads installed. Consult Submersible Service Hotline at 800.348.2420 for information regarding replacement leads.

Specifications subject to change without notice. Contact Franklin Electric if current material types are required for bid specifications.



Franklin Electric

400 E. Spring Street, Bluffton, Indiana 46714

Tel: 260 824 2900 Fax: 260 824 2909

www.franklin-electric.com