



BAUER

FOR A GREEN WORLD



RAINSTAR

The Austrian BAUER group – head office located Voitsberg, Styria – is the dominant force in irrigation technology and the global market leader thanks to the RAINSTAR irrigator during the last 40 years.

- BAUER RAINSTAR – a range of models designed to accommodate any size and shape of farming system
- Cost and energy saving irrigation – user-friendly – optimum performance and reliability
- Quality workmanship – decades of experience in the manufacture of irrigation machines – particularly attractive price-performance ratio
- Laser-machined precision-toothed chain sprockets ensure precise chain drive and high reliability
- Pipe reel and steelwork fully hot galvanised – high quality corrosion protection ensures lasting value and high resale value
- Modern design – central control, easily accessible unit with irrigation computer
- New radial full flow turbine – cost and energy saving irrigation, particularly efficient when low precipitation rates are applied
- Raingun trolley with automatic angle compensator for uneven ground and trolley inlet
- The RAINSTAR E55 completes the 11 RAINSTAR models offered with over 80 different pipe lengths



The compact series for cost saving irrigation

RAINSTAR T

- Revolving pipe reel – with integrated hydraulic leg supports
- 2 wheel chassis with adjustable track width and mechanical jack
- Energy saving BAUER full flow turbine TVR 20 (T51 – T61) with BAUER 4-speed gearbox
- Newly developed turbine TVR 18 (T32 – T42) with BAUER 4-speed gearbox
- Irrigation computer ECOSTAR 4300 with back up battery and solar panel for exact precipitation rates and high performance and reliability
- User friendly – hydraulic jack, unit connection on both sides, central control unit, hydraulic gun trolley lift (together with supports)
- Gun trolley with automatic angle compensation – keeps the Rainer in an ideal position, on uneven rough ground
- Special BAUER PE-pipe – High form stability and tensile strength





RAINSTAR T61
with options

RAINSTAR T32
with options

Specification									
Model	Type	PE-pipe dia. mm	PE-pipe length m	Strip width m	Consumption m ³ /h	Nozzle sizes mm	Connection press bar	Weight kg	
								with water	less water
T32	65 - 270	65	270	53 - 68	14 - 35	14.0 - 22.0	3.5 - 11.0	2060	1407
	65 - 320	65	320	53 - 68	14 - 35	14.0 - 22.0	3.5 - 11.0	2227	1452
	65 - 350	65	350	53 - 67	14 - 31	14.0 - 20.0	3.5 - 11.0	2325	1479
	75 - 250	75	250	53 - 76	14 - 49	14.0 - 26.0	3.5 - 11.0	2269	1460
	75 - 280	75	280	53 - 76	14 - 49	14.0 - 26.0	3.5 - 11.0	2401	1496
	75 - 300	75	300	53 - 75	14 - 44	14.0 - 24.0	3.5 - 11.0	2489	1520
T42	75 - 330	75	330	53 - 75	14 - 44	14.0 - 22.0	3.5 - 11.0	2622	1555
	85 - 220	85	220	55 - 87	17 - 64	16.0 - 28.0	3.5 - 11.0	2412	1538
	75 - 350	75	350	53 - 75	14 - 39	14.0 - 22.0	3.5 - 11.0	2781	1650
	85 - 270	85	270	53 - 83	14 - 60	14.0 - 28.0	3.5 - 11.0	2767	1672
	85 - 300	85	300	53 - 83	14 - 60	14.0 - 28.0	3.5 - 11.0	2937	1720
	85 - 320	85	320	53 - 83	14 - 55	14.0 - 26.0	3.5 - 11.0	3051	1752
T51	90 - 260	90	260	55 - 90	17 - 73	16.0 - 30.0	3.5 - 11.0	2889	1718
	90 - 280	90	280	55 - 88	17 - 71	16.0 - 30.0	3.5 - 11.0	3016	1775
	90 - 300	90	300	55 - 86	17 - 69	16.0 - 30.0	3.5 - 11.0	3144	1792
	75 - 400	75	400	53 - 71	14 - 33	14.0 - 20.0	3.5 - 11.0	3577	2309
	75 - 420	75	420	53 - 71	14 - 33	14.0 - 20.0	3.5 - 11.0	3666	2349
	85 - 350	85	350	53 - 83	14 - 55	14.0 - 26.0	3.5 - 11.0	3796	2325
T61	85 - 370	85	370	53 - 80	14 - 52	14.0 - 26.0	3.5 - 11.0	3910	2378
	90 - 330	90	330	55 - 86	17 - 69	16.0 - 30.0	3.5 - 11.0	3909	2334
	90 - 350	90	350	55 - 87	17 - 64	16.0 - 28.0	3.5 - 11.0	4037	2389
	85 - 400	85	400	53 - 76	14 - 49	14.0 - 26.0	3.5 - 11.0	4040	2443
	85 - 450	85	450	53 - 76	14 - 44	14.0 - 24.0	3.5 - 11.0	4324	2592
	90 - 370	90	370	55 - 83	17 - 60	16.0 - 28.0	3.5 - 11.0	4124	2449
	90 - 390	90	390	55 - 83	17 - 55	16.0 - 26.0	3.5 - 11.0	4251	2512
	90 - 420	90	420	55 - 83	17 - 55	16.0 - 26.0	3.5 - 11.0	4442	2615
	90 - 450	90	450	55 - 80	17 - 52	16.0 - 26.0	3.5 - 11.0	4633	2714
	100 - 300	100	300	55 - 90	17 - 73	16.0 - 30.0	3.5 - 11.0	4126	2462
100 - 330	100	330	55 - 90	17 - 73	16.0 - 30.0	3.5 - 11.0	4362	2531	
100 - 350	100	350	55 - 86	17 - 69	16.0 - 30.0	3.5 - 11.0	4519	2577	

Dimensions							
Model	Height mm	Width mm	Length with trolley	Length less trolley	Clearance mm	Tyres	Track width mm
T32	2600	1950	5370	3720	260	195/70 R14	1500
T42	2850	1950	5370	3720	275	205 R 14 C	1500
T51	3140	2298	5306	4045	275	205/R 14C	-
T61	3180	2298	5306	4045	310	10.5/75-15.3	1500 - 2000

Hitch mounting mm		
		
380	660	200x167
400	680	200x173
430	710	200x182
570	850	417

The high-quality series – a continuing success

RAINSTAR E

- Revolving pipe reel with integrated hydraulic leg supports
- 2 wheel chassis with adjustable track width and mechanical jack
- Energy saving BAUER full flow turbine TVR 60
- Irrigation computer ECOSTAR 4300 with back up battery and solar panel for exact precipitation rates, high performance and reliability
- User friendly – hydraulic jack, HK108 unit connection on both sides, central command unit, hydraulic gun trolley lift (together with supports)
- BAUER 4-speed gearbox with brake and tractor PTO rewind
- Gun trolley with automatic slope compensation – keeps the raingun in an ideal position on uneven rough ground
- Special BAUER PE-pipe – high form stability and tensile strength



RAINSTAR E41
with options

Specification									
Model	Type	PE-pipe dia. mm	PE-pipe length m	Strip width m	Consumption m ³ /h	Nozzle sizes mm	Connection press bar	Weight kg	
								with water	less water
E11	90 - 480	90	480	54 - 75	17 - 44	16.0 - 24.0	4.5 - 11.0	5595	3548
	100 - 350	100	350	58 - 94	22 - 77	18.0 - 30.0	4.5 - 11.0	5290	3307
	100 - 380	100	380	58 - 90	22 - 73	18.0 - 30.0	4.5 - 11.0	5526	3391
	100 - 400	100	400	58 - 90	22 - 69	18.0 - 30.0	4.5 - 11.0	5683	3515
	110 - 300	110	300	80 - 112	41 - 112	25.0 - 37.5	4.5 - 11.0	5392	3350
	110 - 330	110	330	77 - 109	35 - 105	20.0 - 35.0	4.5 - 11.0	5677	3450
110 - 350	110	350	75 - 106	33 - 98	22.5 - 35.0	4.5 - 11.0	5867	3506	
E21	100 - 430	100	430	58 - 87	22 - 64	18.0 - 28.0	4.5 - 11.0	6156	3878
	100 - 450	100	450	54 - 83	17 - 55	16.0 - 26.0	4.5 - 11.0	6313	3940
	110 - 350	110	350	75 - 105	33 - 92	22.5 - 35.0	4.5 - 11.0	6105	3744
	110 - 380	110	380	75 - 105	33 - 92	22.5 - 35.0	4.5 - 11.0	6390	3855
	110 - 400	110	400	75 - 103	33 - 92	22.5 - 35.0	4.5 - 11.0	6580	3946
	110 - 420	110	420	75 - 102	33 - 84	22.5 - 35.0	4.5 - 11.0	6770	4027
E31	120 - 300	120	300	80 - 115	41 - 118	25.0 - 37.5	4.5 - 11.0	6115	3813
	100 - 480	100	480	54 - 83	17 - 55	16.0 - 26.0	4.5 - 11.0	6648	4219
	100 - 500	100	500	54 - 83	17 - 55	16.0 - 26.0	4.5 - 11.0	6805	4275
	100 - 520	100	520	54 - 80	17 - 52	16.0 - 26.0	4.5 - 11.0	6962	4391
	110 - 450	110	450	73 - 100	28 - 80	20.0 - 32.5	4.5 - 11.0	7154	4334
	110 - 470	110	470	73 - 99	28 - 80	20.0 - 32.5	4.5 - 11.0	7345	4399
E41	110 - 490	110	490	73 - 97	28 - 78	18.0 - 30.0	4.5 - 11.0	7535	4486
	125 - 310	125	310	80 - 115	41 - 118	25.0 - 37.5	4.5 - 11.0	6682	4183
	125 - 350	125	350	80 - 114	41 - 112	25.0 - 37.5	4.5 - 11.0	7173	4351
	100 - 550	100	550	54 - 80	17 - 52	16.0 - 26.0	4.5 - 11.0	7787	5093
	100 - 590	100	590	54 - 78	17 - 50	16.0 - 26.0	4.5 - 11.0	8101	5248
	110 - 500	110	500	58 - 86	22 - 69	18.0 - 30.0	4.5 - 11.0	8219	5215
E51	110 - 520	110	520	66 - 87	28 - 69	20.0 - 30.0	4.5 - 11.0	8409	5284
	110 - 550	110	550	66 - 87	28 - 69	20.0 - 28.0	4.5 - 11.0	8694	5455
	120 - 420	120	420	75 - 109	33 - 103	22.5 - 35.0	4.5 - 11.0	8217	5045
	120 - 450	120	450	75 - 108	33 - 98	22.5 - 35.0	4.5 - 11.0	8557	5158
	125 - 370	125	370	80 - 115	41 - 118	25.0 - 37.5	4.5 - 11.0	8008	4888
	125 - 400	125	400	80 - 115	41 - 118	25.0 - 37.5	4.5 - 11.0	8376	5003
E51	140 - 340	140	340	80 - 118	41 - 124	25.0 - 37.5	4.5 - 11.0	8855	5302
	110 - 590	110	590	58 - 83	22 - 65	18.0 - 30.0	4.5 - 11.0	8982	5552
	110 - 620	110	620	58 - 80	22 - 52	18.0 - 26.0	4.5 - 11.0	9267	5698
	110 - 650	110	650	58 - 80	22 - 52	18.0 - 26.0	4.5 - 11.0	9552	5892
	120 - 530	120	530	75 - 103	33 - 92	22.5 - 35.0	4.5 - 11.0	9369	5532
	120 - 550	120	550	75 - 103	33 - 88	22.5 - 32.5	4.5 - 11.0	9595	5705
	120 - 570	120	570	75 - 103	33 - 85	22.5 - 32.5	4.5 - 11.0	9822	5837
	120 - 600	120	600	76 - 102	33 - 80	22.5 - 32.5	4.5 - 11.0	10160	6050
	125 - 450	125	450	80 - 112	41 - 112	25.0 - 37.5	4.5 - 11.0	8897	5161
	125 - 500	125	500	75 - 108	33 - 98	22.5 - 35.0	4.5 - 11.0	9511	5480
140 - 400	140	400	80 - 118	41 - 124	25.0 - 37.5	4.5 - 11.0	9533	5599	

Dimensions							Hitch mounting mm			
Model	Height mm	Width mm	Length with trolley	Length less trolley	Clearance mm	Tyres	Track width mm			
E11	3480	2530	7600	5450	340	11.5/80-15.3	1800	223	- 498	2250
E21	3480	2560	7730	5580	340	11.5/80-15.3	1800	229	- 504	2250
E31	3530	2560	7730	5580	340	12.5/80-15.3	1800	235	- 510	2250
E41	3730	2670	8120	6160	340	12.5/80-15.3	1800	270	- 545	2250
E51	4070	2670	8200	6230	360	12.5/80-15.3	1800	340	- 620	2250

Compact - economic – powerful

RAINSTAR E55

- Pipe reel can be lowered hydraulically and swivelled 360° – pull-out possible in each direction
- 4-wheel chassis with tandem swing axle for lower ground pressure and uniform weight distribution
- Separately controlled Hydraulic machine supports, adjust to uneven ground
- Energy saving BAUER full flow turbine TVR 60
- Irrigation computer ECOSTAR 4300 with back up battery and solar panel for exact precipitation rates, high performance and reliability
- User friendly – hydraulic jack, HK 108 unit connection on both sides, central command unit
- BAUER 4-speed gearbox with brake and tractor PTO rewind
- Raingun trolley with automatic slope compensation – keeps the sprinkler in an ideal position on uneven ground
- BAUER PE-pipe – high form stability and tensile strength

10 soccer fields in one irrigation run – with max 700 m pipe length, 115 m irrigation width and performance in excess of 110 m³/h



Plant Protection

Despite the large 3.5 m diameter of the drum, the unit is very compact. The PE pipe is lowered hydraulically and the drum then pivots a full 360°. Thanks to minimal space requirements, the unit causes little damage to plants.



Firmly anchored to the ground

Strong, hydraulic supports anchor the unit to the ground. The overall construction is extremely strong and suited for retraction forces up to 40% stronger when compared to competitors similar offerings.

Specification									
Model	Type	PE-pipe dia. mm	PE-pipe length m	Strip width m	Consumption m ³ /h	Nozzle sizes mm	Connection press bar	Weight kg	
								with water	less water
E55	110 - 700	110	700	65 - 82	25 - 55	18.0 - 26.0	5.0 - 11.0	10820	6993
	120 - 650	120	650	75 - 98	33 - 72	22.0 - 32.5	5.0 - 11.0	11521	7064
	125 - 620	125	620	80 - 103	40 - 88	25.0 - 35.0	5.0 - 11.0	11779	7097
	140 - 460	140	460	80 - 115	40 - 110	25.0 - 37.5	5.0 - 11.0	11251	6727

RAINSTAR E55 with options

Dimensions							
Model	Height mm	Width mm	Length with trolley	Length less trolley	Clearance mm	Tyres	Track width mm
E55	3800	3000	8260	5290	270	400/60	2690/5.5

Power and economy in one drive unit

Turbine TVR 60 and TVR 20

The radial full-flow economy turbine TVR 60 (E models) and TVR 20 (T models) with the unique Vario nozzle is a power pack and energy saver in one.

Extremely low pressure loss helps to save money, particularly when low precipitation & hence water-saving rates are applied.

Advantages – precise regulation plus broad performance range, even with high retraction speeds.

Comparing efficiency levels

The extremely high efficiency level of the BAUER turbine, plus excess performance capacity & minimal pressure loss during normal range operation, ensures reliability and extensive savings under particularly difficult operating conditions ie: compared to turbines of competitors.

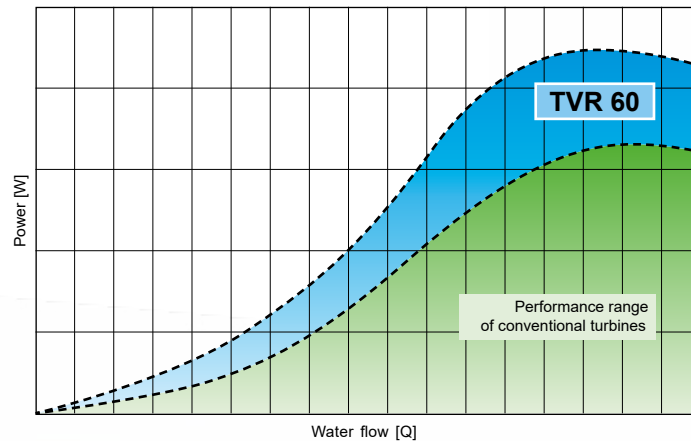

Pinpoint precision assembly results in the highest operating efficiency. Each individual part of the high-tech turbine is engineered in the head-quarters at Voitsberg. The turbine is assembled by highly qualified technicians. Prior to being fitted to the RAINSTAR, the turbine's quality and performance are tested on a highly modern engine test bench.

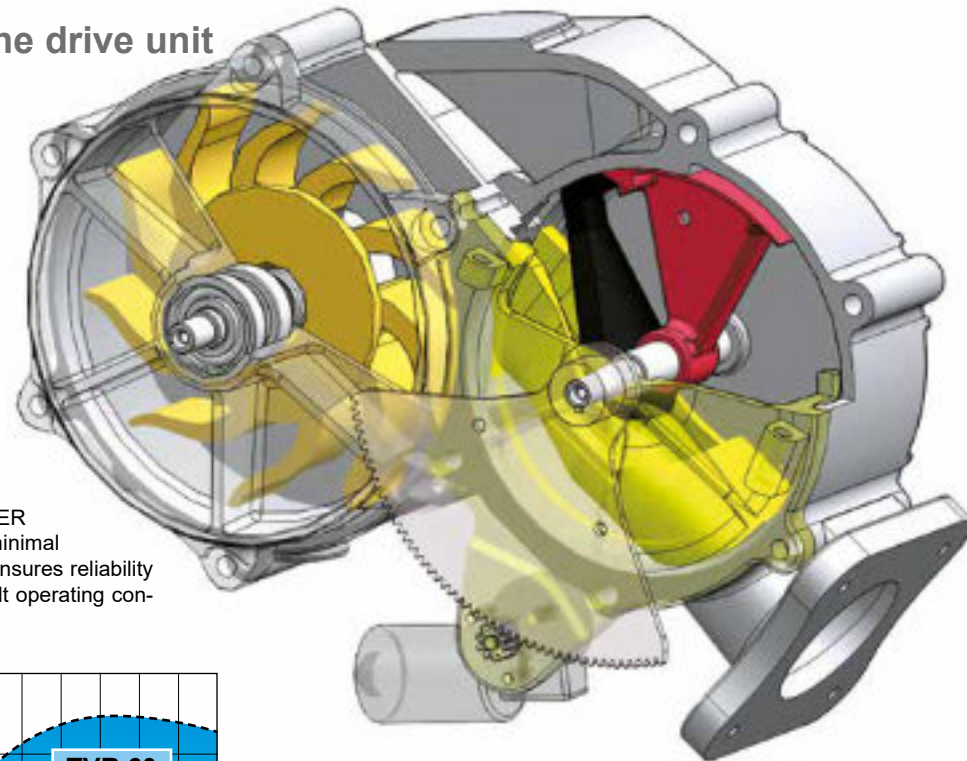

Computer-controlled regulation

The regulation of the turbine is controlled electronically. The Vario nozzle keeps the retraction speed constant from the beginning to the end of the strip, with precise & optimum pressure utilisation.

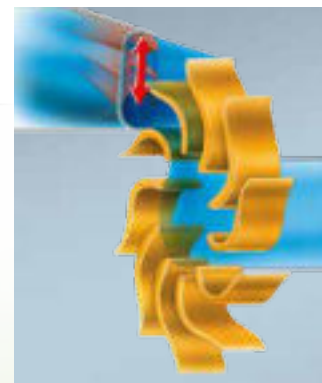

Vario nozzle

Maximum use of output is achieved by direct flow from the Vario nozzle onto the impeller. At maximum and minimum nozzle settings, the full stream flows over the turbine's impeller. This ensures the highest efficiency and minimum pressure loss at all flow rates.

Irrigation control on a high-tech level

Cost savings thanks to highest efficiency

The drive train of the BAUER RAINSTAR is design optimised in every detail. This ensures highest efficiency, reliability and ease of operation.

A v-belt transfers the turbine's concentrated power without energy loss direct to the BAUER 4-speed gearbox. 4 different transmission gear ratios ensure the turbine operates at cost saving maximum efficiency.

The power required to rewind the PE-pipe onto the large-diameter pipe reel is transmitted via a high strength, high quality chain plus a laser-machined precision-toothed gear sprocket. The retraction power is evenly distributed over a large surface area, due to the expanded outer diameter of the chain wheel & higher density of gear-teeth sprockets.

At the end of the irrigated strip, the drive gear is disengaged automatically, and the power transmission is stopped. The aerated drum brake is placed directly on the drive & ensures highest security during road transport.

ECOSTAR 4300

- Easy operation at the push of one button
- 4-line display
- Irrigation status indication
- Permanent set-actual speed comparison
- Solar panel +12V battery
- Real-time clock-start time indication
- Operation-hour counter
- Variable irrigation speed zones
- Precipitation indicator
- Input and output for SMS control

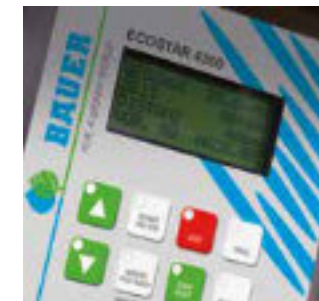

SMS for ECOSTAR 4300

- Status information
- START and STOP of the machine
- Change of retraction speed
- Error messages

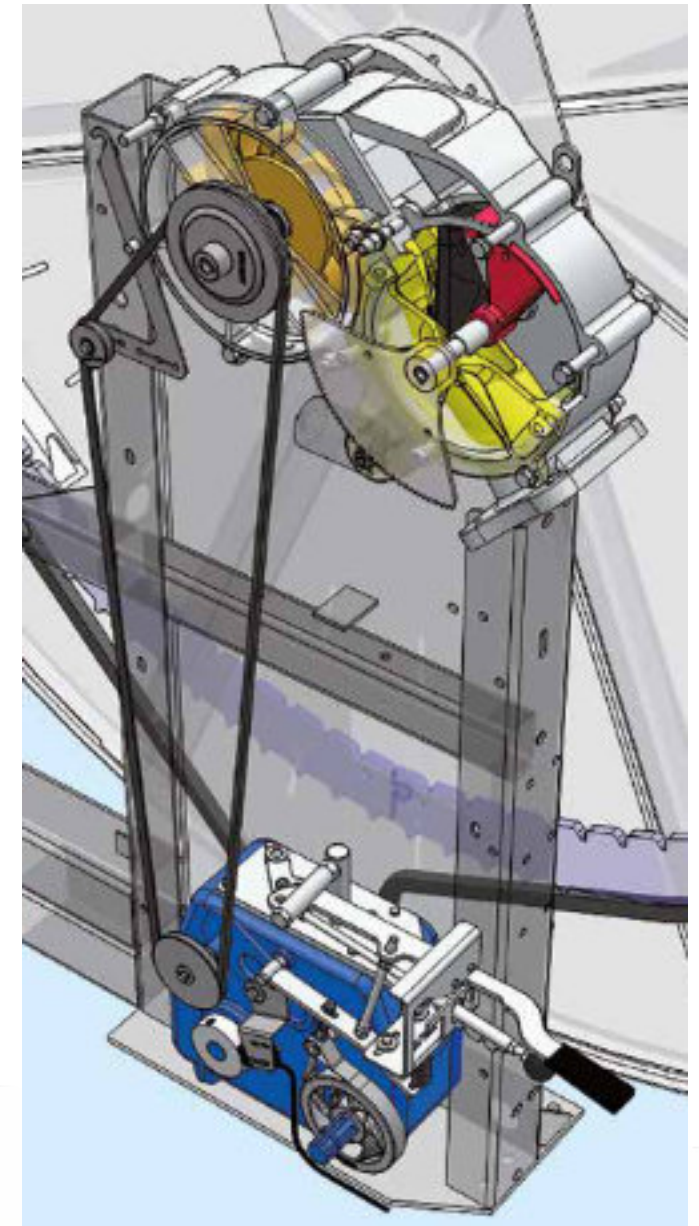

Comfortable gear changes with precise shift gate and indication of the gear selected. Safe and simple gear-shift. The safety lock on the clutch lever prevents changing gear while the drive is engaged.

Safety has priority!

Certified engine production standards, following the highest quality requirements for high durability and maximum reliability.



Convincing arguments for successful irrigation



Galvanisation

Hot dip galvanising to pipe drum, turntable and undercarriage.

Optimum corrosion protection for long lasting value and durability.

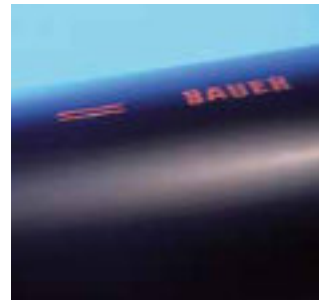

PE-pipe manufacture

In house PE-pipe production with special granulate material for highest strength & quality.

Maximum durability under toughest demands. The ideal wall thickness for low pressure loss and high energy savings.



Fully rolled inner reel drum

The inner reel drum of each RAINSTAR is fully closed and equipped with a pipe guiding device.

The first layer of the PE pipe sits on the drum evenly & without distortion. The pipe is gently guided into the right position for each layer.



Serial production

RAINSTAR T and RAINSTAR E models are manufactured in large production line runs.

Highly qualified personnel and cutting-edge manufacturing technology ensure consistent high quality and reliable spare parts availability.

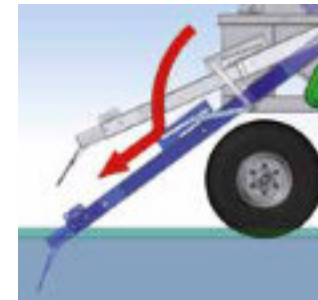

Sturdy machine supports

The specific kinematics and the flat angle of the hydraulic unit supports direct the forces into the machine's centre.

The machine is immovably anchored to the ground – even with retraction forces up to 40% higher than those of similar machines of competitors.



Winding gear

The PE pipe is gently layered by a double guided winding mechanism & precisely driven by a helically grooved spindle.

Total precision layering ensures the trouble-free operation and a longer service life of the PE-pipe.

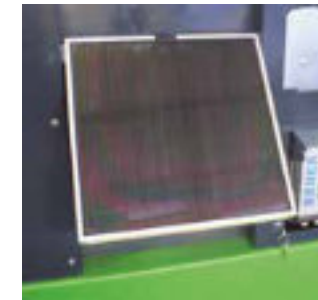

Solar panel

The high-performance solar panel generates a reliable power supply.

As part of the standard supply spec, the solar panel is used for charging the 12V battery, this ensures maintenance-free operation, independent of other power sources.



Precision chain drive

Precision-manufactured drive sprocket for the reel drive ensure even distribution of forces on a large surface area.

High-performance drive chains guarantee maintenance-free operation and long service, even with high retraction forces.



Electronic shut-off valves

Choose between over pressure and low pressure valve. Both types of shut-off are available for the RAINSTAR.

The ideal set-up for your operational requirements. Shut-off can be used for single pumping units and closed ring mains.

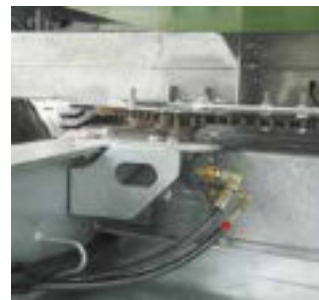

Hydraulic swivel aid

Hydraulic turn the entire pipe reel via a massive sprocket and powerful hydraulic motor drive.

Turn the reel drum to the desired position with ease – even on rough ground.



4-wheel tandem axle

Tandem swing axle with high clearance or chassis with rigid axles and very low centre of gravity.

Swing axle as well as 4-wheel chassis provide an even weight distribution and low ground pressure, protecting crops.



Gun trolley anchor

Fully automatic, hydraulically controlled trolley anchor for easy laying down of the PE-pipe in any type of crop.

At the start of the irrigation process, the anchor is fully & automatically set into the ground. This is easy and time-efficient irrigation.



Pipe guide mechanism for laying down the PE-pipe

User-friendly, hydraulic pipe guide mechanism lays down the PE-pipe precisely between plant rows.

The PE-pipe is guided by a specially designed device and laid down in the desired position by hydraulic control units without any strain.



Blow out device

The PE-pipe is exhausted via an original BAUER compressor and ball matching the pipe diameter.

Easier road transport and energy savings during pull-out of the PE-pipe. For machines with large dia PE pipe.



ECOSTAR 4300 + SMS

High-tech irrigation control. Live check the operational status, plus start and stop the machine via SMS.

Monitor different RAINSTAR machines independent of your location – this is ultra convenient and time-saving irrigation management.

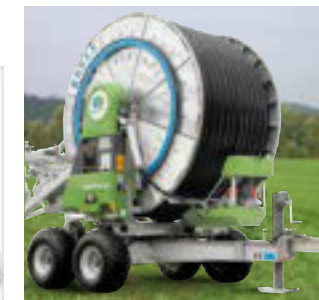

RAINSTAR with hydraulic drive

External drive with hydraulic motor for distribution of viscous liquids, such as sludge and slurry.

Compact and user-friendly hydraulic unit offers precise precipitation control plus high retraction speeds.



Protecting soil and crops

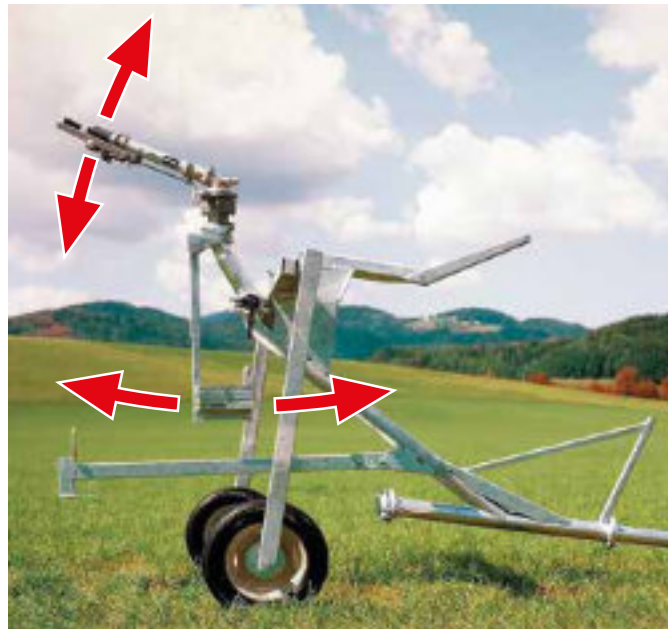

Crop-saving angle compensation

Keeps the Rain-gun properly inclined on uneven ground, especially during the final rewind. Saves the crop from potential water jet damage.

Crop-protecting Rain-gun Trolley

The multi-talented gun trolley: infinitely adjustable track width, symmetric or asymmetric PE-pipe retraction (easy swap), high clearance. Prevents damage in taller crops. Large diameter tyres guarantee reliable pull-out & retraction in difficult soil and crop conditions.

Cart lift

At the end of the irrigated strip the Gun trolley & unit support legs are hydraulically retracted into the transport position (E models). Automatic Gun trolley loading at strip end (T models).



Laying the PE-pipe in crop rows

For in-field operation, the Rainstar wheel tracks adjust exactly to suit the crop row spacing. A special guide ensures the PE-pipe is laid out in a straight line between the plant rows. Tractor, Rainstar & Gun Trolley move in precisely the same alignment, eliminating crop damage.



Irrigation in its finest form



Boom trolley AS50 / AS 32

Spray booms apply a particularly fine mist, equally protecting the crop and soil structure. Spray jet's require a very low operating pressure. The result is an economical use of both energy and water.

The AS 50 boom trolley matches exactly with RAINSTAR E models and applies a gentle precipitation mist on strip widths up to 72 m.

The boom trolley is made of high-quality steel and aluminium components, in spite of this light construction the ground stability is excellent.

Special weights continuously balance the boom parallel to the ground. An infinitely variable hydraulic height adjustment provides ground clearance from 1.3 m to 2.3 m (AS 50) ie: the system is also ideal for higher crops.

The AS 32 Spray boom was specifically designed for use with RAINSTAR T machines & covers strip widths up to 50 m.

A compact transport unit, easy to handle

For transport the folding arms of the AS 50 or AS 32 are loaded on the RAINSTAR. A single operator easily opens or closes the boom in just a few minutes.

Positioning from one irrigated strip to the next is simple, the fully open boom is hoisted like the gun trolley and requires no further attention.

360° rotating aid on AS 50

With the rotation aid the system can be adjusted precisely to suit irregular fields. Roads running diagonally along the border of a field are not obstructed by projecting boom arms. Also ideal for avoiding trees, power line supports and other similar field obstacles.

Wheel cart dimensions

Basic model	Track width height	Wheel cart symmetric mm	Wheel cart asymmetric mm	Tyre dimension
T31 and T41	W	1200 – 3000 (3800)	1200 – 2000	165/70 R13
	H	1100	1100	
T51 and T61	W	1200 – 3000 (3800)	1200 – 2000	165/70 R13
	H	1100	1100	
E11 / E51 and E61 S/H	W	1500 – 3900	1500 – 2000	165/70 R13
	H	1600	1600	

Wheel cart symmetric

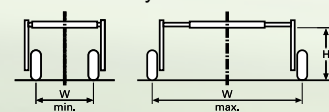

Wheel cart asymmetric

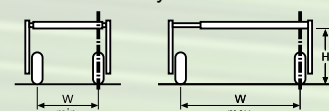

Spray nozzles

A low 0.8 bar nozzle pressure is sufficient to produce exceptionally fine and gentle rain that protects both crops and soil. Added advantages are significantly lower pressure requirement (saving up to 4 bar), uniform distribution, and low sensitivity to wind drift.

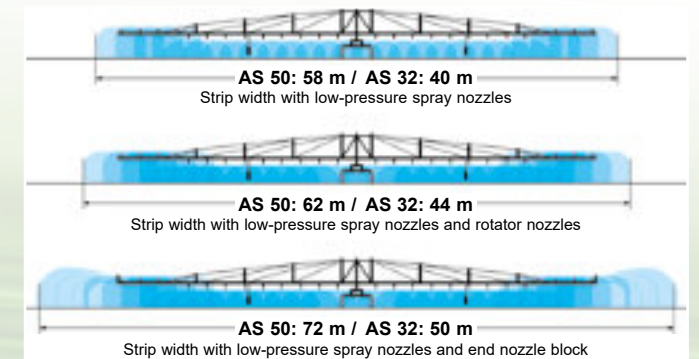



BAUER

FOR A GREEN WORLD

Broad base single source supply



Your Dealer:

Röhren- und Pumpenwerk BAUER Ges.m.b.H.
8570 Voitsberg, Austria
Tel. +43 3142 200-0
Fax +43 3142 200-320 / -340 sales@bauer-at.com
www.bauer-at.com

A **BAUER Group** company